

Dear Hyundai Owner:

This notice is sent to you in accordance with the requirements of the National Traffic and Motor Vehicle Safety Act.

Hyundai has decided that a defect, which relates to motor vehicle safety, exists in certain model year 2005 through 2008 Hyundai vehicles.

Federal law requires that any vehicle lessor receiving this recall notice must forward a copy of this notice to the lessee within ten days.

What is the problem?

"The stop lamp switch in the affected vehicles may malfunction. A malfunctioning stop lamp switch may cause the brake lights to not illuminate when the brake pedal is depressed or may cause the brake lights to remain illuminated when the brake pedal is released. A stop lamp switch malfunction may affect the operation of the brake-transmission shift interlock feature so the transmission shifter would not be able to be shifted out of Park position. It may also cause the electronic stability control (ESC) malfunction light to illuminate, and it may not deactivate the cruise control when the brake pedal is depressed. These malfunctions may lead to a crash.

What will Hyundai do?

"To ensure that your vehicle's stop lamp switch operates properly, we are asking you to schedule an appointment as soon as possible to take your vehicle to your Hyundai dealer. The Hyundai dealer will replace your vehicle's stop lamp switch. This procedure will be performed at no charge to you. You should plan to leave your vehicle at your Hyundai dealer to have this service performed. Repair times will vary and depend on your dealer's appointment schedule.

What should you do?

"We urge you to call your Hyundai dealer to schedule an appointment to have this work performed as soon as possible.

What if you have other questions?

"If you have any difficulty having this repair performed, we recommend that you call the Hyundai Customer Assistance Center at 1-800-633-5151. If you are still not satisfied that we have remedied this situation without charge, and within a reasonable amount of time, you may wish to write to the Administrator, National Highway Traffic Safety Administration, 1200 New Jersey Avenue, SE, Washington, D.C. 20590, or call their toll-free Vehicle Safety Hotline at 1-888-327-4236 (TTY: 1-800-424-9153), or go to <http://www.safercar.gov>.

We urge your prompt attention to this important safety matter.

Hyundai Motor America

June 24, 2009

TO:ALL HYUNDAI DEALER PRINCIPALS/GENERAL MANAGERS:
ALL HYUNDAI DEALERSHIP SERVICE MANAGERS:
ALL HYUNDAI DEALERSHIP PARTS MANAGERS:
ALL HYUNDAI DEALERSHIP SALES MANAGERS:

SUBJECT: Recall Campaign 092 - Stop Lamp Switch Replacement - TSB# 09-01-018

Hyundai Motor America is conducting a Customer Notification for replacement of the Stop Lamp Switch on certain model years and production dates of the following models: Accent, Tucson, Sonata, Elantra, Santa Fe, Veracruz, Azera, and Entourage.

This campaign provides a procedure for the replacement of the Stop Lamp Switch.

In order to identify only those vehicles affected by Campaign 092, it will be necessary to access Hyundai Motor America's "Warranty Vehicle Information" screen via WEBDCS before starting the repair. The "Warranty Vehicle Information" screen will identify affected vehicles with an open Campaign 092.

Dealer Letter, Customer Letter, and Technical Service Bulletin #9-01-018 will be posted on Hyundai's Website June 24, 2009.

All Hyundai dealers will be shipped a supply of Stop Lamp Switches identified in the Technical Service Bulletin. Additional Stop Lamp Switches can be ordered from your Facing PDC.

Customer notification letters will be mailed in weekly flights starting Monday, June 29, 2009.

It is IMPORTANT TO SUBMIT A CAMPAIGN CLAIM FOR EACH VEHICLE SERVICED so your dealership can be compensated for your work and Hyundai can maintain accurate records of campaign completions.

LEGAL LIABILITY NOTICE: You are required to keep confidential any and all information and documents provided to you by Hyundai Motor America in the conduct of carrying out work for this recall campaign. Hyundai Motor America dealers may use owner information provided for the campaign only for the purpose of conducting and performing this recall campaign, and for no other purpose.

Hyundai appreciates your cooperation and support. Questions may be directed to your District Parts and Service Manager or Warranty HELPREP line at 1-877-446-2922.

HYUNDAI MOTOR AMERICA



HYUNDAI Technical Service Bulletin

		Group		CAMPAIGN
		Number		09-01-018
Subject		Date		JUNE, 2009
		Model		SEE BELOW
STOP LAMP SWITCH REPLACEMENT (CAMPAIGN 092)				
CIRCULATE TO:	<input type="checkbox"/> GENERAL MANAGER	<input checked="" type="checkbox"/> PARTS MANAGER	<input checked="" type="checkbox"/> TECHNICIAN	
<input checked="" type="checkbox"/> SERVICE ADVISOR	<input checked="" type="checkbox"/> SERVICE MANAGER	<input checked="" type="checkbox"/> WARRANTY MGR	<input type="checkbox"/> SALES MANAGER	

IMPORTANT: DEALERS MUST PERFORM THIS CAMPAIGN ON ALL AFFECTED VEHICLES WHENEVER AN AFFECTED VEHICLE IS IN THE SHOP FOR ANY MAINTENANCE OR REPAIR.

IMPORTANT: WHEN A VEHICLE ARRIVES AT THE SERVICE DEPARTMENT, ACCESS HYUNDAI MOTOR AMERICA'S "WARRANTY VEHICLE INFORMATION" SCREEN VIA WEBDCS TO IDENTIFY OPEN CAMPAIGNS.

1. DESCRIPTION:

This TSB describes the procedure to remove, replace, and adjust the stop lamp switch.

NOTE: During replacement of the Accent (MC), Elantra (HD), Tucson (JM), Sonata (NF), Azera (TG), Veracruz (EN) and Santa Fe (CM) stop lamp switches, do not remove the crash pad lower cover (driver's side), but before replacement of the Entourage (EP) stop lamp switch, the crash pad lower cover should be removed for easy access.

NOTE: Before replacement of Entourage stop lamp switches on vehicles with adjustable brake pedals, the stop lamp switch bracket mounting nuts and the crash pad lower cover should be removed in advance. For the detailed procedure, refer to the SERVICE PROCEDURE in this bulletin.

NOTE: When replacing the Santa Fe (CM) 2.7L stop lamp switches, use the supplied service kit which includes an additional extension wire.

2. VEHICLES AFFECTED - VERIFY THAT THE VEHICLE IS IDENTIFIED AS AFFECTED BY THE CAMPAIGN VIA WEBDCS:

Model: Accent (MC), Elantra (HD), Sonata (NF), Azera (TG), Tucson (JM), Santa Fe (CM), Veracruz (EN), Entourage (EP).

Applicable vehicle production date range:



Model	Production Range
Accent (MC)	Oct. 13, 2005 ~ Mar. 31, 2006
	Oct. 20, 2006 ~ Nov. 30, 2006
Tucson (JM)	Apr. 4, 2005 ~ Feb 28, 2006
	Oct. 20, 2006 ~ Apr. 30, 2007
Sonata (NF)	Mar. 1, 2005 ~ Feb. 28, 2007
Elantra (HD)	Oct. 25, 2006 ~ Apr. 30, 2007
Santa Fe (CM)	Oct. 20, 2006 ~ Mar. 31, 2007
Veracruz (EN)	Dec. 26, 2006 ~ Nov. 30, 2007
Azera (TG)	Sep. 20, 2006 ~ Nov. 30, 2006
Entourage (EP)	Feb. 16, 2006 ~ Mar. 31, 2006
	Oct. 20, 2006 ~ Jan. 31, 2007



HYUNDAI Technical Service Bulletin

Group	CAMPAIGN
Number	09-01-018

3. PARTS REQUIRED:

Part Name	Figure	Part Number		Remark
		Previous	New	
Switch Assy - Stop Lamp		93810-3K000	93810-3K000QQH	Connector body color change: Black (previous) -> Gray (new) For MC, HD, NF/ NFA, TG, JM, EN, and 3.3L CM/ CMA
		93810-38110		
Service Kit - Stop Lamp Switch		93810-0W000 (3.3L CMA)	93810-0W000QQH (3.3L CMA)	Stop lamp switch & extension wire 2.7L CM/CMA
			93810-3K300QQH (2.7L CM)	
Switch Assy - Stop Lamp			93810-3K400QQH	Switch and connector color: Black (previous) -> Gray (new) For EP

COMPONENTS:

1. Stop Lamp Switch Assembly
2. Stop Lamp Switch Connector
3. Stop Lamp Switch Plunger
4. Brake Pedal Stopper
5. Stop Lamp Switch Lock Nut

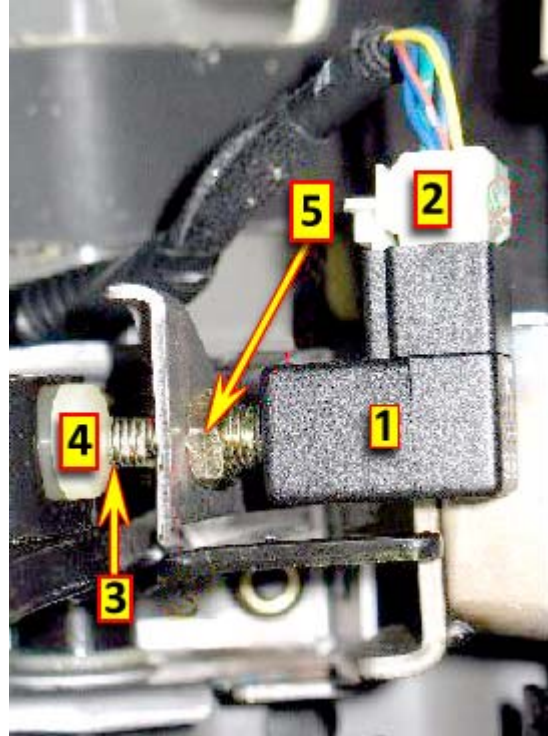

4. SERVICE PROCEDURE:

NOTE: Before conducting the procedure, verify that the vehicle has an open campaign 092 identified on WEBDCS.

NOTE: The below procedure is for Accent (MC), Elantra (HD), Sonata (NF), Azera (TG), Tucson (JM), Veracruz (EN) and Santa Fe (CM) vehicles without need to remove the crash pad lower cover for the stop lamp switch replacement.



HYUNDAI Technical Service Bulletin

Group

CAMPAIGN

Number

09-01-018

1. Move the driver's seat rearward all the way.
2. Turn the ignition switch to the OFF position.



3. Locate the stop lamp switch connected to the brake pedal assembly underneath the dash on the driver side.

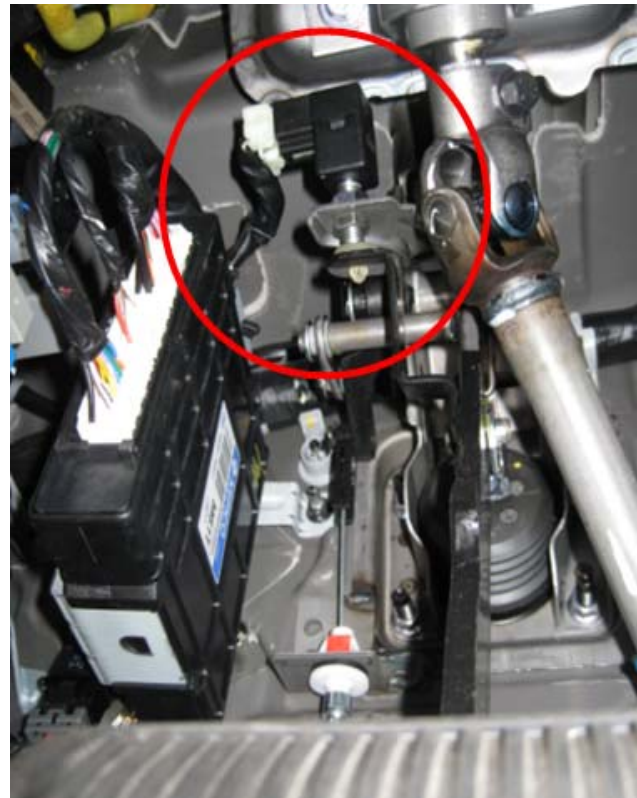

4. Loosen lock nut and remove the stop lamp switch from its mount. Disconnect the connector and remove the stop lamp switch from the vehicle.

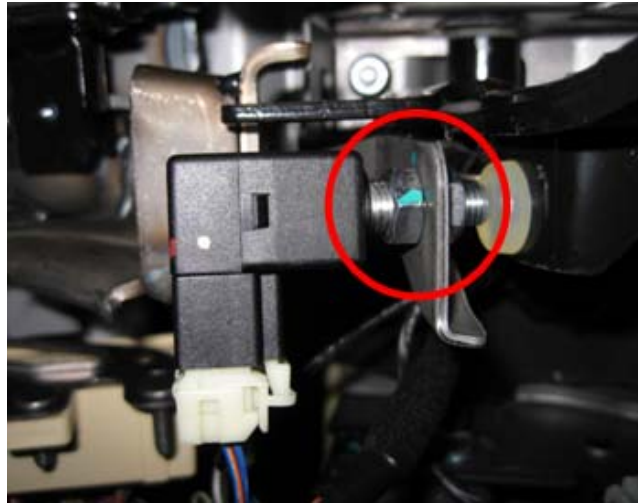

5. Install the new part. Adjust the clearance according to specification:

Specification: A-B = 1.5 - 2.0 mm

A - Stop Lamp Switch Metal Housing

B - Brake Pedal Stopper

NOTE: Before installing the replacement part, check the part number packaging to ensure the appropriate part is installed.

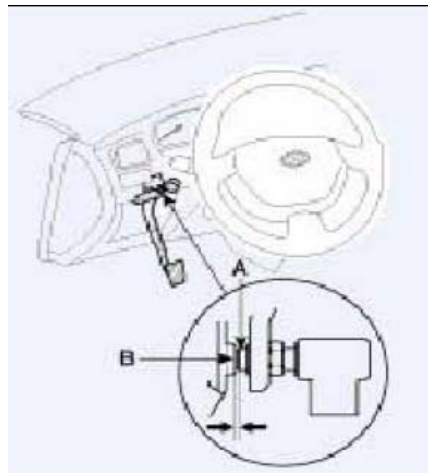



HYUNDAI Technical Service Bulletin

Group	CAMPAIGN
Number	09-01-018

INSTRUCTIONS FOR ENTOURAGE (EP):

1. Move the driver's seat rearward all the way and turn the ignition switch to the OFF position.
2. Remove the crash pad side cover and fuse box cover.
3. Remove the parking brake cable release lever (A).
4. Remove the crash pad lower cover (B).



5. Remove the 'T' bar (C) from under the steering wheel.



6. Remove the air duct (D).
7. Disconnect the stop lamp switch connector (E).

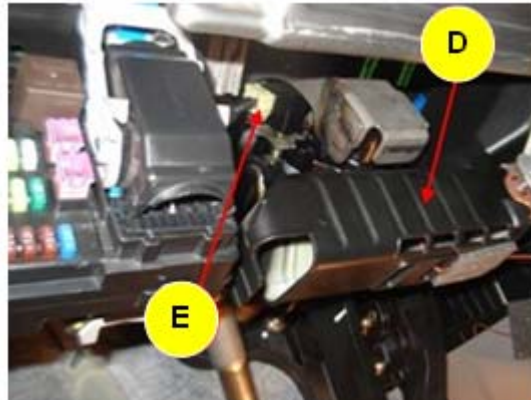

8. When removing the stop lamp switch in Entourage (EP) vehicles equipped with adjustable-height pedals, it may be required to loosen a mounting bracket to provide enough space to remove the stop lamp switch.



9. Loosen the two nuts holding the bracket in place. This will create enough space to remove the stop lamp switch.
10. Install the new switch, set the adjustment clearance, and reinstall all removed panels to complete the procedure.





INSTRUCTIONS FOR 2.7L SANTA FE (CM):

1. For 2.7L-equipped CM Santa Fes, install the supplied stop lamp switch service kit (B).

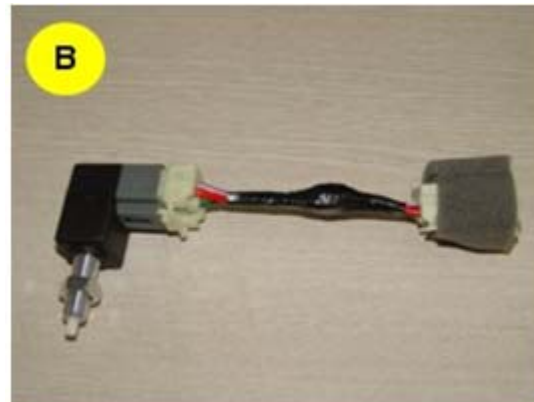

2. The photo at the right shows the stop lamp switch service kit being fitted in the bracket and the mating wiring connector.

- C: Extension wire
- D: Stop lamp switch assembly

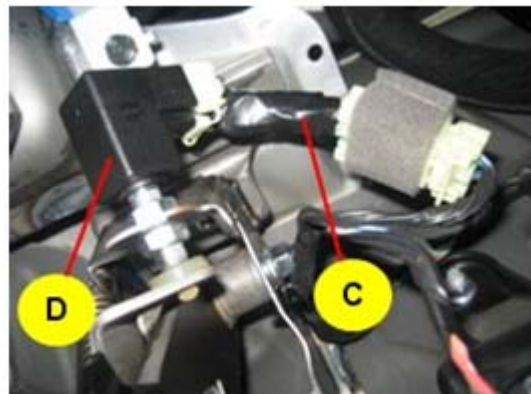

SPECIAL INSTRUCTIONS FOR VERACRUZ (EN) EQUIPPED WITH HEIGHT ADJUSTABLE BRAKE PEDAL:

1. Ensure that the clearance between the relay box (J) and stop lamp switch (K) is **15mm or greater**. Adjust by slightly pulling on the relay box and wiring.

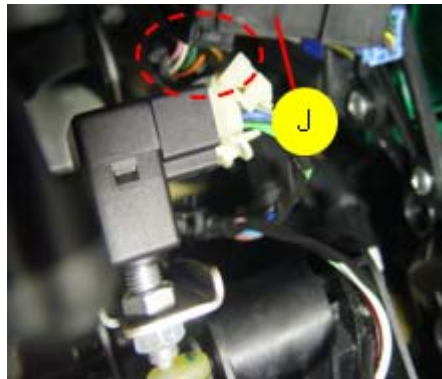
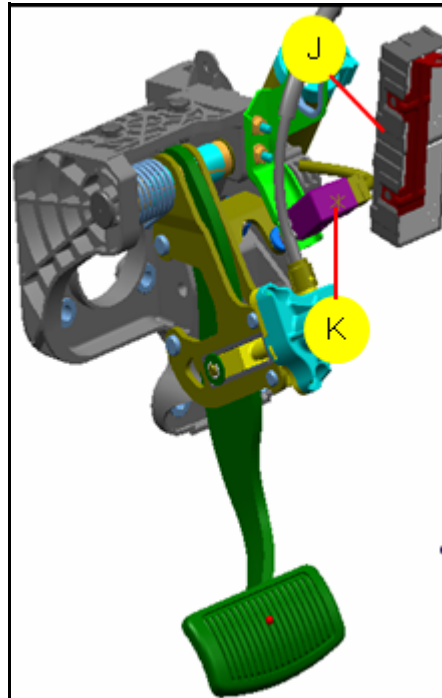

5. WARRANTY CLAIM INFORMATION:

Op Code	Model	Description	Op Time
91B026R0	MC, HD, NF/NFA, TG, JM, EN, CM/CMA	Stop lamp switch assembly replacement	0.2 M/H
91B026R1	EP with non-adjustable pedal		0.3 M/H
91B026R2	EP with adjustable pedal		0.5 M/H

NOTE: Submit claim on Campaign Entry Screen.